

Fork Capacities (lb)								
Load Center	in	24	36	48	60	72	84	96
No. of Counterweights	0	49,770	42,010	36,350	32,030	28,630	25,880	23,610
	1	61,310	51,750	44,780	39,460	35,270	31,880	29,090
	2	72,850	61,490	53,200	46,880	41,900	37,880	34,560
	3	84,380	71,230	61,630	54,310	48,540	43,880	40,040
	4	95,920	80,970	70,060	61,730	55,180	49,880	45,510
	5	107,460	90,710	78,480	69,160	61,810	55,880	50,990
	6	119,000	100,450	86,910	76,580	68,450	61,880	56,460
	7	130,540	110,190	95,340	84,010	75,090	67,880	61,930
	8	142,080	119,940	103,760	91,340	81,730	73,940	67,510
	9	153,620	127,680	106,220	94,200	81,370	73,940	67,510
	10	160,000	133,000	115,000	103,000	81,370	73,940	67,510

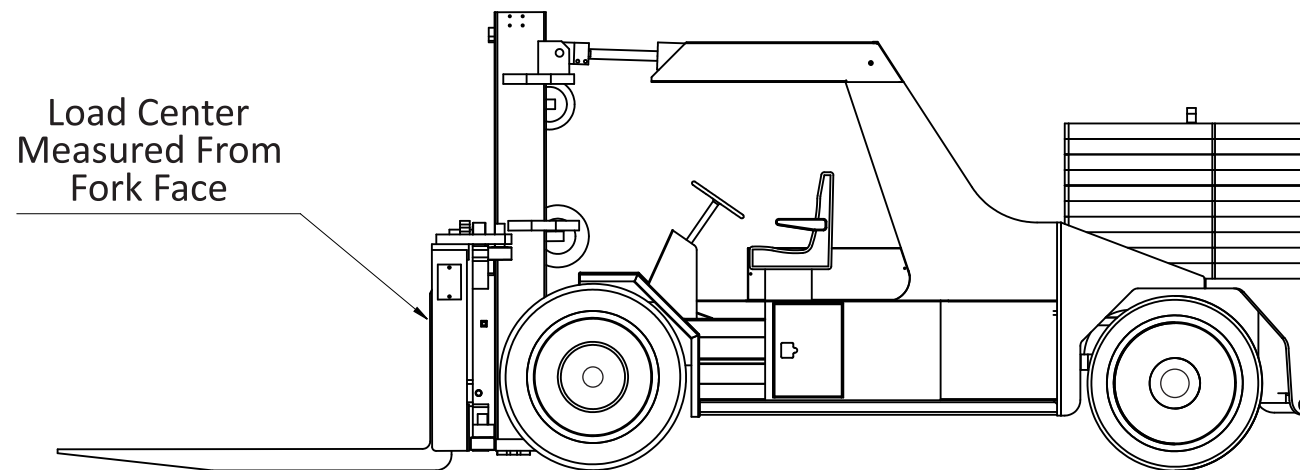

Boom Capacities (lb)												
Load Center	in	12	24	36	48	60	72	84	96	108	120	132
No. of Counterweights	0	48,710	40,970	35,350	31,090	27,740	25,040	22,830	20,970	19,390	18,030	16,860
	1	60,600	50,970	43,980	38,670	34,510	31,160	28,400	26,090	24,130	22,440	20,970
	2	72,490	60,970	52,610	46,260	41,280	37,270	33,970	31,210	28,860	26,840	25,080
	3	84,380	70,970	61,230	53,850	48,050	43,380	39,540	36,330	33,590	31,240	29,200
	4	96,270	80,970	69,860	61,440	54,820	49,500	45,110	41,440	38,330	35,640	33,310
	5	108,160	90,970	78,490	69,020	61,600	55,610	50,690	46,560	43,060	40,050	37,430
	6	120,050	100,970	87,120	76,610	68,370	61,720	56,260	51,680	47,790	44,450	41,540
	7	131,940	110,970	95,750	84,200	75,140	67,840	61,830	56,800	52,530	48,850	45,660
	8	140,000	120,970	104,380	91,790	81,910	73,950	67,400	61,920	57,260	53,250	49,770
	9	145,000	125,000	107,500	93,500	83,000	74,500	67,400	61,920	57,260	53,250	49,770
	10	155,000	130,000	111,000	95,000	84,000	75,000	67,400	61,920	57,260	53,250	49,770

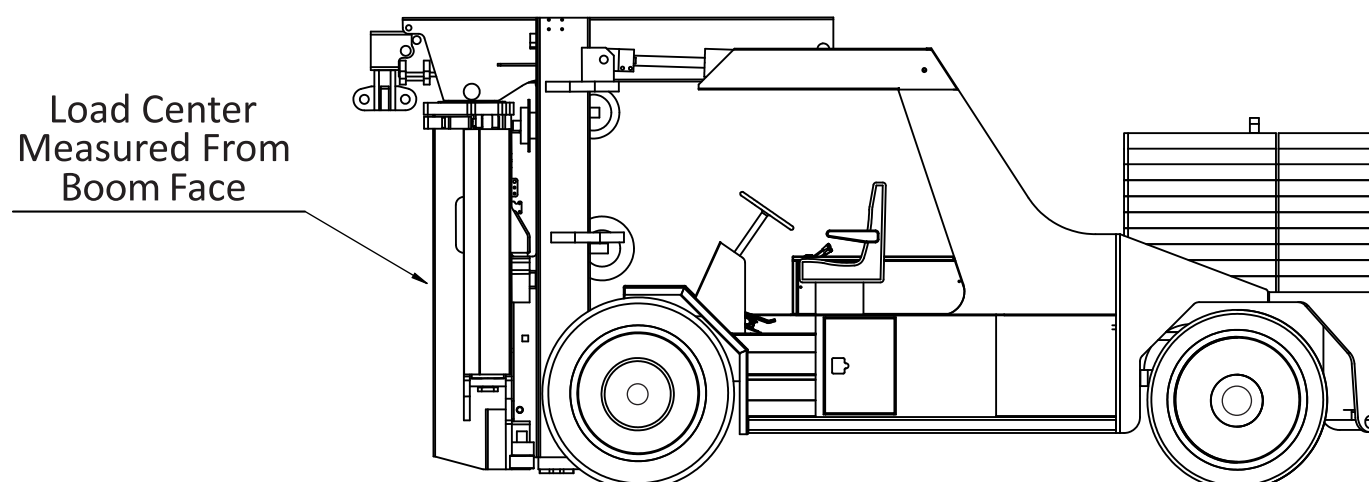

**\*CAPACITIES RATED WITH MAST VERTICAL**