

ORION⁺ 60K

POWER, PERFORMANCE & PRECISION

62,500 lbs. maximum capacity [28,000 kgs.]



- Orion's quick-change attachment systems
- Durable components for long, dependable life
- Smooth, controlled hydrostatic drive
- Powerful V8, LP power
- Made in Canada 🇨🇦



highreachinc.com

orionlifts.com

ORION⁺ 60K

POWER, PERFORMANCE & PRECISION

Component Weights:

Chassis w/forks & all ctwts:	55,540 lbs.	Forks/carriage:	3,450 lbs.
Front:	17,500 lbs.	Boom:	7,360 lbs.
Rear:	38,040 lbs.	Boom & Stand:	8,160 lbs.
Chassis w/o ctwts, w/forks:	31,290 lbs.	Counterweights:	4,850 lbs. x 5 each
Front:	17,500 lbs.	Total Ctwts:	24,250 lbs.
Rear:	13,790 lbs.		

Boom Specifications

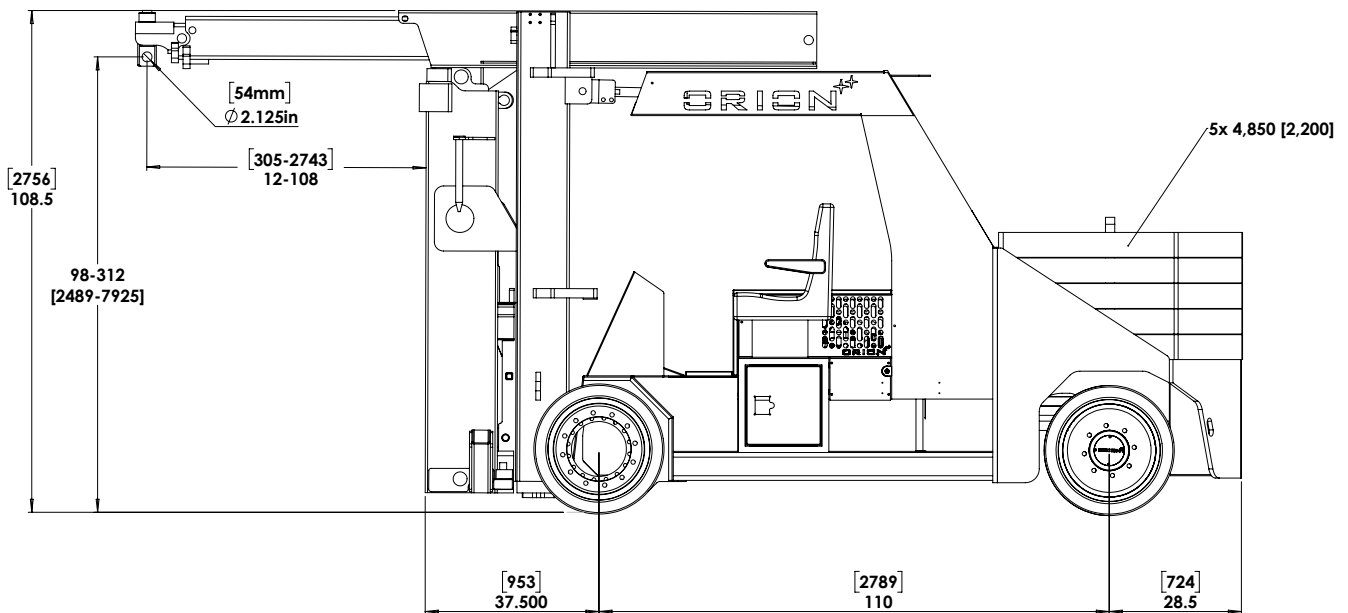

Weight As Shown Above: 57,120 LBS [25,963 kg]

Rated Boom Capacities (lbs.)									
LC in Inches >	12"	24"	36"	48"	60"	72"	84"	96"	108"
0 CWT	23,000	18,500	15,400	13,300	11,600	10,300	9,300	8,500	7,800
1 CWT	31,200	25,000	21,000	18,000	15,800	14,000	12,700	11,500	10,600
2 CWT	39,350	31,600	26,500	22,700	19,900	17,700	16,000	14,500	13,300
3 CWT	47,400	38,000	31,900	27,400	24,000	21,400	19,300	17,500	16,000
4 CWT	55,500	44,600	37,300	32,000	28,100	25,000	22,600	20,500	18,800
5 CWT	60,000	48,000	40,400	34,700	30,400	27,000	24,000	21,800	20,000

*CAPACITIES RATED WITH MAST VERTICAL

ORION⁺ 60K

POWER, PERFORMANCE & PRECISION

62,500 lbs. @ 24" w/Sideshift

43,300 lbs. @ 48" w/Sideshift

Lift Height (clear): 102"
 Free Lift: 32 1/2"
 Standard Forks dimensions: 96" x 10" x 4 1/2"
 Max distance between standard forks: 48"
 Max distance outside-to-outside forks: 68"
 Min distance between forks: 4"
 Max lift height w/boom: 26'
 Max horizontal reach w/boom: 9'
 Travel Height: 108.5"

Overall Width: 72"
 Overall Length: 168.5"
 Wheelbase: 110"
 Engine/Fuel: 5.7L LP GM Industrial
 Hydrostatic Pump: Danfoss
 Gradability: 20% loaded 50% unloaded
 Tires Front: 28" x 20" x 22" non-marking
 Tires Rear: 28" x 10" x 22" non-marking

Forklift Specifications

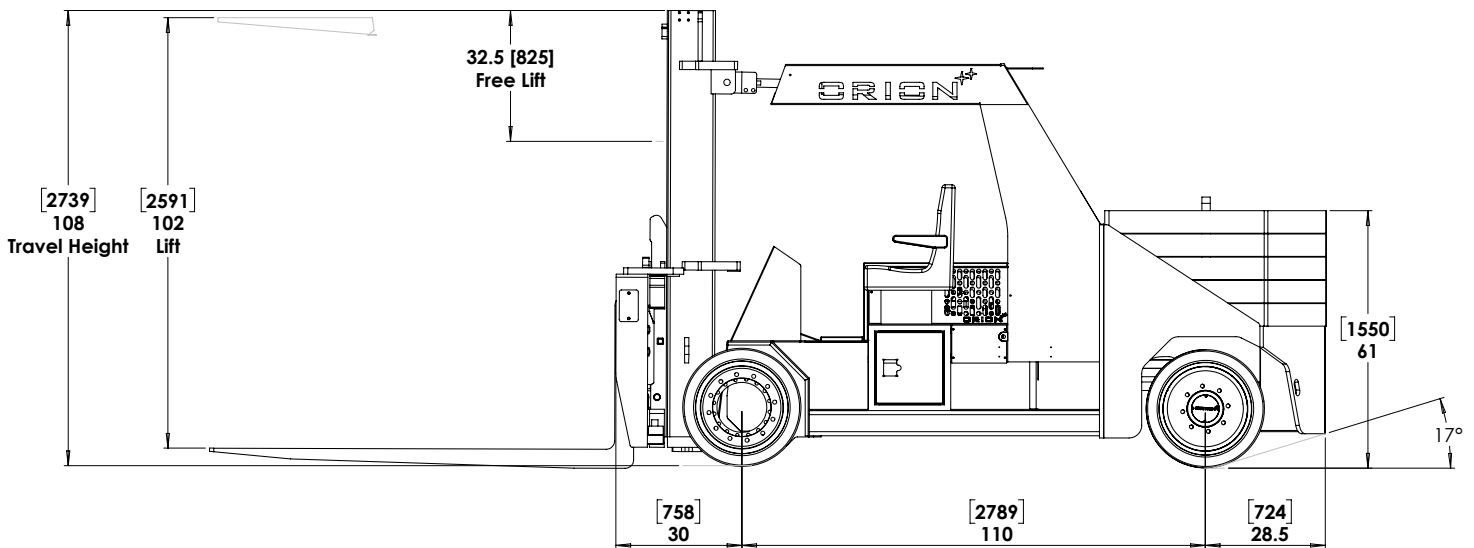

Weight As Shown Above: 55,540 lbs [25,245 kg]

Rated Fork Capacities (lbs.)					
LC in Inches >	24"	36"	48"	60"	72"
0 CWT	23,000	15,300	13,000	11,200	9,900
1 CWT	30,900	25,200	21,400	18,500	16,300
2 CWT	38,800	31,800	26,900	23,300	20,500
3 CWT	46,700	38,200	32,300	28,000	24,700
4 CWT	54,600	44,700	37,800	32,800	28,900
5 CWT	62,500	51,200	43,300	37,500	33,100

*CAPACITIES RATED WITH MAST VERTICAL

ORION^{✦✦} 60K

POWER, PERFORMANCE & PRECISION

ORION 60K features:

- ✓ The Orion Quick Change Riggers' Boom is safer and faster to install AND it improves boom lifting capacities.
- ✓ Full-power fork locators align the forks where you need them, when you need them, effortlessly.
- ✓ Side-shifting carriage permits safer, faster, more accurate placement of big, heavy loads.
- ✓ Rugged design, durable construction, and long-life components.
- ✓ Tilt and roll angle sensors.

Optional Equipment:

- ✓ Various Fork Sizes
- ✓ Coil prong or Coil forks
- ✓ Extra-wide/custom carriage
- ✓ Full-function (steer, drive, lift) Digital, Radio Remote Control
- ✓ Tall Mast (129" travel & 144" lift height with 52.5" free lift)
- ✓ Back up Camera



Orion Quick-Change (Boom to Forks in < 10 min.)



Tilt-steering, ergonomic seating, easy-read, light-touch controls



Easy-Read Load Scale. Keep track of how much you've lifted.



Very Low Lift LP Tank Loading. Improves safety immensely.



 **High Reach Inc.**[✦]

High Reach Inc., 480 Wyecroft Road, Oakville, Ontario, L6K 2G7 Canada
T: 905-844-4164 • www.highreachinc.com